





# A IR-TO-WATER



## SERIES LINE-UP

Mitsubishi Electric have a good variety of units depending on conditions for installation sites.

PACKAGED TYPE				
Water heat exchanger is built in the outdoor units.				
	2HP	3HP	4HP	5HP
Power Inverter	 PUHZ-W50VHA(-BS)*	 PUHZ-W85VHA(-BS)*		
ZUBADAN For cold regions			 PUHZ-HW112YHA(-BS)*	 PUHZ-HW140VHA(-BS)* / PUHZ-HW140YHA(-BS)*

\* Model names including "BS" are highly rust resistant. e.g.) PUHZ-W50VHA-BS

OPTIONAL PARTS LIST									
Outdoor Units	Optional Part	Step Interface <sup>3)</sup>		Flow Temperature Controller <sup>3)</sup>			Thermistor	Connector for Drain Hose Heater Signal Output	
		10 PC Boards w/o Case	1 PC Board w/ Case	10 PC Boards w/o Case	1 PC Board w/ Case	1 PC Board w/ Case			
		PAC-IF010-E <sup>2)</sup>	PAC-IF011B-E	PAC-IF020-E <sup>2)</sup>	PAC-IF021B-E	PAC-IF031B-E			
Packaged Type	Power Inverter	PUHZ-W50VHA	○	○	○	○	○	○ <sup>1)</sup>	○
		PUHZ-W50VHA-BS	○	○	○	○	○	○ <sup>1)</sup>	○
		PUHZ-W85VHA	○	○	○	○	○	○ <sup>1)</sup>	○
		PUHZ-W85VHA-BS	○	○	○	○	○	○ <sup>1)</sup>	○
	ZUBADAN	PUHZ-HW112YHA	○	○	○	○	○	○ <sup>1)</sup>	○
		PUHZ-HW112YHA-BS	○	○	○	○	○	○ <sup>1)</sup>	○
		PUHZ-HW140VHA	○	○	○	○	○	○ <sup>1)</sup>	○
		PUHZ-HW140VHA-BS	○	○	○	○	○	○ <sup>1)</sup>	○
		PUHZ-HW140YHA	○	○	○	○	○ <sup>1)</sup>	○	
		PUHZ-HW140YHA-BS	○	○	○	○	○ <sup>1)</sup>	○	

Notes: 1) PAC-IF010-E or PAC-IF020-E is required.  
 2) PAC-IF010-E and PAC-IF020-E are only for manufacturer's preloading.  
 3) Step interface or Flow Temperature Controller is required to operate units. Which you should select depends on local system configuration.

CONTENTS			
Part Name	Model Name	Contents	Q'ty
Step Interface	PAC-IF011B-E	PC Board	1
		Case	1
		Thermistor	2
Flow Temperature Controller	PAC-IF021B-E	PC Board	1
		Case	1
		Thermistor	2
	PAC-IF031B-E	Remote Controller	1
		Remote Controller Cable (5m)	1
		PC Board	1
		Case	1
		Thermistor	3
		Remote Controller	1
Remote Controller Cable (5m)	1		
Interface	PAC-IF010-E	PC Board	10 <sup>1)</sup>
Flow Temperature Controller	PAC-IF020-E	PC Board	10 <sup>1)</sup>
Thermistor	PAC-TH010-E	Thermistor	20 <sup>2)</sup>

Notes: 1) One carton contains 10 PC boards. 2) Two thermistors per package; 10 packages per carton.

# AIR-TO-WATER

This series of extremely efficient air-to-water heat pumps incorporates numerous original air conditioning technologies developed by Mitsubishi Electric. The eco-friendly units offer the perfect combination of powerful heating and cooling performance and economical running cost.



## The Secret Behind Our Stellar Heat Pump Efficiency is Capturing the Heat that is Already in the Air.

Heat pump systems are now capturing attention as a decisive catalyst in efforts to conserve energy. With this technology, atmospheric heat is harnessed; that is, it is collected from the air and used as a heat source to provide highly efficient heating. For example, a heat pump with a coefficient of performance (COP) of 4.0 uses 1kW of electrical energy input and 3kW of heat energy transferred from outside-air to the heat pump for an impressive final heat output of 4kW.

### Air-to-Water Heat Pump Principle (when heating)

Refrigerant and Heat Circulation  
< Case of COP 4.0 >

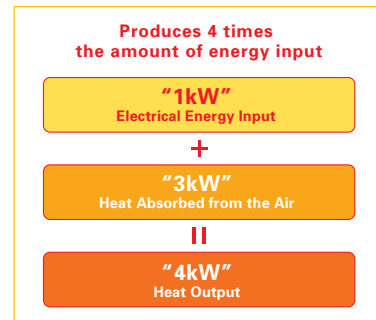
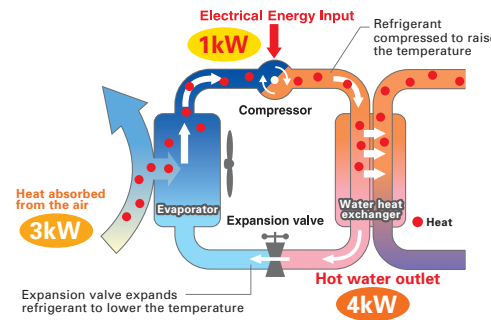

## Drastic Reductions in Operation Cost and CO<sub>2</sub> Emissions – No Sacrifice in Comfort

Heat pumps differ from conventional heat sources in their ability to effectively use atmospheric heat. A unit with a COP of 4.0 has a heat output of 4kW for each kilowatt of electricity consumed. This contributes to a major reduction in operating cost when compared to other heating sources on the market.

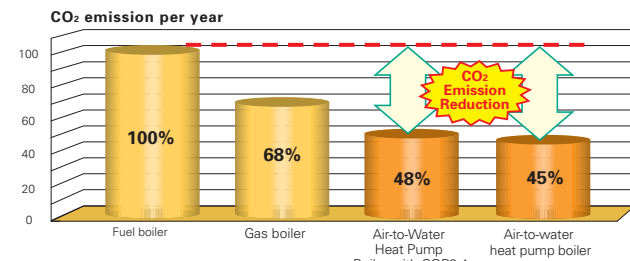

Source: A coefficient of CO<sub>2</sub> emission based on Ministry of the Environment Japan data.

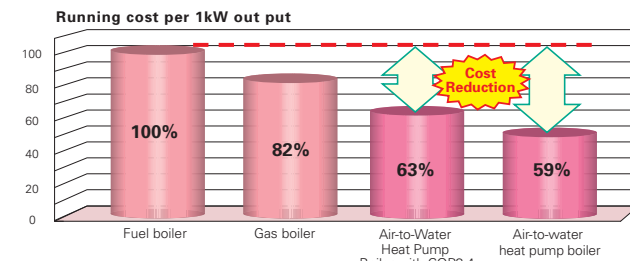

Source: Energy prices based on EUROSTAT data.

## No Need for Refrigerant Piping

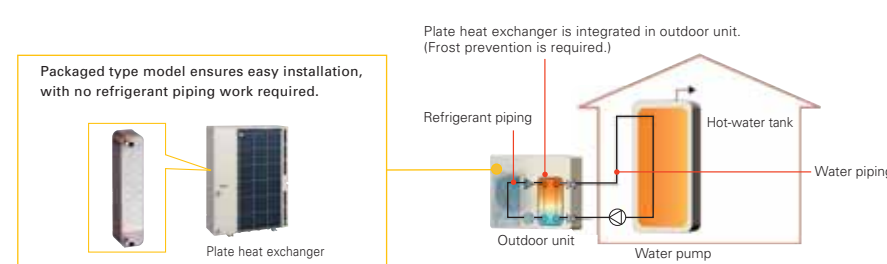

## Interface (Option)

Two types of interface are available. Select the one that best fits your needs.

## Improved Heating Performance



Mitsubishi Electric's unique "Flash Injection Circuit" is a key component in the high heating performance of the ZUBADAN. This technology enables the rated heating capacity to exceed that of the power inverter series by 30%, even when operating with sub-zero temperatures outdoors, and the guaranteed operating range of the heating mode is extended to -25°C. Thanks to ZUBADAN technologies, Air-to-water heat pumps can now be used to heat homes in cold regions too.

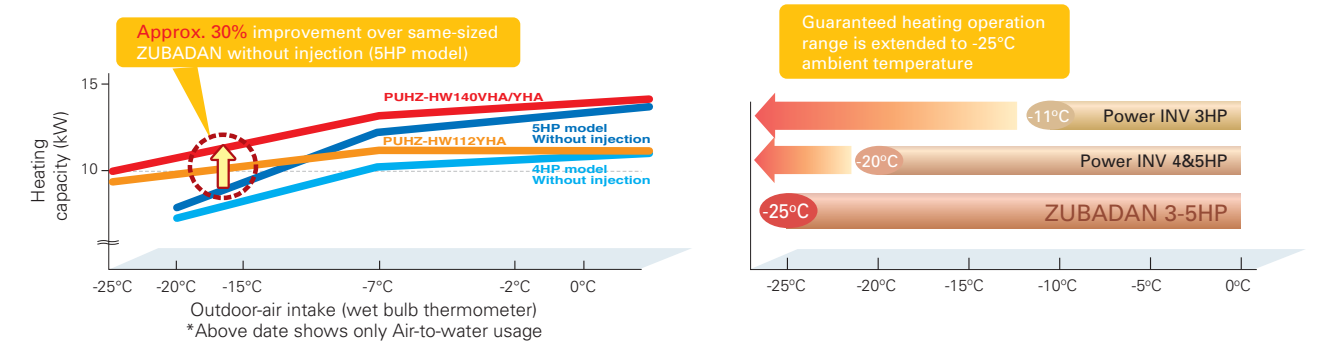

## Mitsubishi Electric's Flash Injection Technology The Key to High Heating Performance at Low Outdoor Temperatures

### Flash Injection Circuit

ZUBADAN

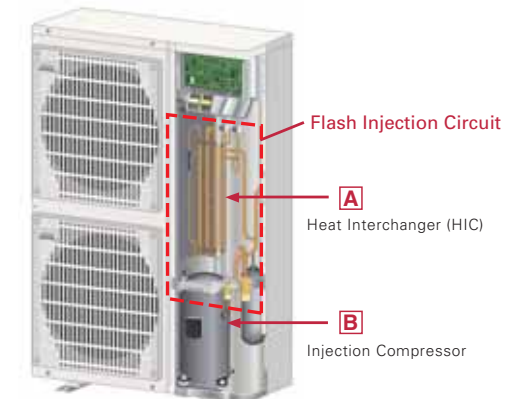
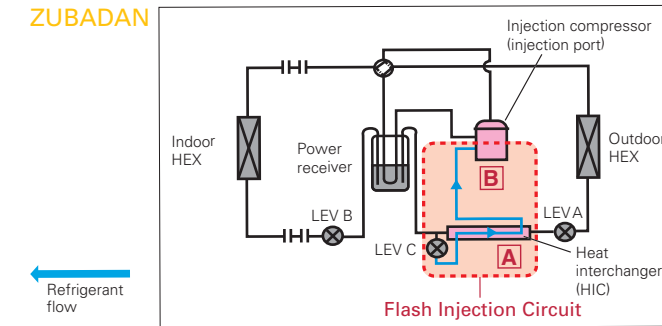

The Mr. Slim model of the ZUBADAN Series is equipped with Mitsubishi Electric's original Flash Injection Circuit, which is comprised of a bypass circuit and heat interchanger (HIC). The HIC transforms rerouted liquid refrigerant into a gas-liquid state to lower compression load. This process ensures excellent heating performance even when the outdoor temperature drops very low. In traditional units, when the outdoor temperature is low, the volume of refrigerant circulating in the compressor decreases due to the drop in refrigerant pressure and protection from overheating due to high compression, thereby reducing heating capacity. The Flash Injection Circuit injects refrigerant to maintain the refrigerant circulation volume and compressor operation load, thereby maintaining heating capacity.

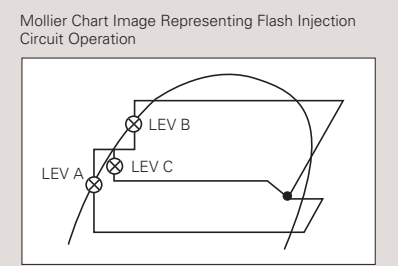

### A Heat Interchanger (HIC)

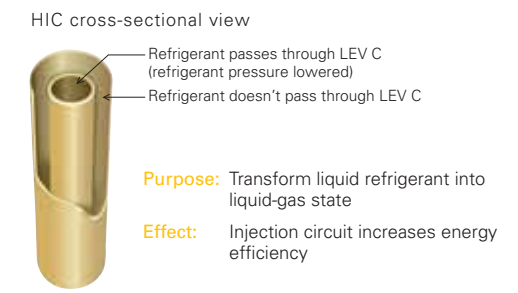

### B Injection Compressor

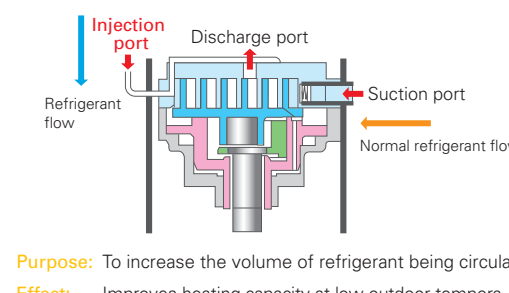

The compressor is subjected to a heavy load when compressing liquid refrigerant, and the result is lower operation efficiency. The addition of HIC supports refrigerant heat exchange at two different pressure levels. The heat-exchange process transforms the injected liquid refrigerant into a gas liquid state, thereby decreasing the load on the compressor during the compression process.

Refrigerant passes from the HIC into the compressor through the injection port. Having two refrigerant inlets makes it possible to raise the volume of refrigerant being circulated when the outdoor temperature is low and at the start of heating operation.

## Packaged Type Specifications

### ■ Power Inverter

Model Name			PUHZ-W50VHA (-BS)	PUHZ-W85VHA (-BS)
Function			Heating and Cooling	Heating and Cooling
Refrigerant			R410A	R410A
Power Supply	Phase	∅	1	1
	Voltage	V	230	230
	Frequency	Hz	50	50
Max running current		A	13	23
Dimensions H x W x D		mm	740 × 950 × 330 (+30 <sup>1)</sup> )	943 × 950 × 330 (+30 <sup>1)</sup> )
Weight		kg	64	77
Noise Levels	Heating (A7/W35)	dB	46 <sup>2)</sup>	48 <sup>2)</sup>
	Cooling (A35/W7)	dB	45 <sup>2)</sup>	48 <sup>2)</sup>
Outlet Water Temp. (Max. heating)		°C	60°	60°
Guaranteed Operating Range (Outdoor)	Heating	°C	-15 – +35	-20 – +35
	Cooling	°C	-5 <sup>3)</sup> – +46	-5 <sup>3)</sup> – +46
Heating (A7/W35)	Capacity	kW	5.00	9.00
	COP		4.10	3.85
	Power Input	kW	1.22 <sup>4)</sup>	2.34 <sup>4)</sup>
	Nominal Water Flow	L/min	14.3	25.8
Heating (A7/W45)	Capacity	kW	5.00	9.00
	COP		3.21	2.97
	Power Input	kW	1.56 <sup>4)</sup>	3.03 <sup>4)</sup>
	Nominal Water Flow	L/min	14.3	25.8
Cooling (A35/W75)	Capacity	kW	4.50	7.50
	EER (COP)		2.94	2.39
	Power Input	kW	1.53 <sup>4)</sup>	3.14 <sup>4)</sup>
	Nominal Water Flow	L/min	12.9	21.5
Cooling (A35/W18)	Capacity	kW	4.50	7.50
	EER (COP)		4.13	3.87
	Power Input	kW	1.09 <sup>4)</sup>	1.94 <sup>4)</sup>
	Nominal Water Flow	L/min	12.9	21.5
Heating pump input (Based on EN14511)		kW	0.01	0.03
Cooling pump input (Based on EN14511)		kW	0.01	0.02

Heating pump input (Based on EN14511)

Cooling pump input (Based on EN14511)

1) Grill

2) 1m from outdoor unit.

3) Operation at outdoor temperature of -15°C is possible using the optional air outlet guide.

4) Based on EN14511, power input figures include pump input figures at the bottom of the table.

### ■ ZUBADAN

Model Name			PUHZ-HW112YHA (-BS)	PUHZ-HW140VHA (-BS)/YHA(-BS)
Function			Heating and Cooling	Heating and Cooling
Refrigerant			R410A	R410A
Power Supply	Phase	∅	3	1/3
	Voltage	V	400	230/400
	Frequency	Hz	50	50
Max running current		A	13	35/13
Dimensions H x W x D		mm	1350 × 1020 × 330 (+30 <sup>1)</sup> )	1350 × 1020 × 330 (+30 <sup>1)</sup> )
Weight		kg	148	134/148
Noise Levels	Heating (A7/W35)	dB	53 <sup>2)</sup>	53 <sup>2)</sup>
	Cooling (A35/W7)	dB	53 <sup>2)</sup>	53 <sup>2)</sup>
Outlet Water Temp. (Max. heating)		°C	60°	60°
Guaranteed Operating Range (Outdoor)	Heating	°C	-25 – +35	-25 – +35
	Cooling	°C	-5 <sup>3)</sup> – +46	-5 <sup>3)</sup> – +46
Heating (A7/W35)	Capacity	kW	11.20	14.00
	COP		4.24	4.19
	Power Input	kW	2.64 <sup>4)</sup>	3.34 <sup>4)</sup>
	Nominal Water Flow	L/min	32.1	40.1
Heating (A7/W45)	Capacity	kW	11.20	14.00
	COP		3.23	3.18
	Power Input	kW	3.47 <sup>4)</sup>	4.40 <sup>4)</sup>
	Nominal Water Flow	L/min	32.1	40.1
Cooling (A35/W75)	Capacity	kW	10.00	12.50
	EER (COP)		2.72	2.59
	Power Input	kW	3.68 <sup>4)</sup>	4.82 <sup>4)</sup>
	Nominal Water Flow	L/min	28.7	35.8
Cooling (A35/W18)	Capacity	kW	10.00	12.50
	EER (COP)		4.07	4.01
	Power Input	kW	2.46 <sup>4)</sup>	3.12 <sup>4)</sup>
	Nominal Water Flow	L/min	28.7	35.8
Heating pump input (Based on EN14511)		kW	0.01	0.02
Cooling pump input (Based on EN14511)		kW	0.01	0.02

Heating pump input (Based on EN14511)

Cooling pump input (Based on EN14511)

1) Grill

2) 1m from outdoor unit.

3) Operation at outdoor temperature of -15°C is possible using the optional air outlet guide.

4) Based on EN14511, power input figures include pump input figures at the bottom of the table.